

SPECIFICATIONS

The decorative base is constructed of two identical cast clamshells A319 alloy aluminum or equivalent.

Connecting hardware are stainless steel socket head style bolts. Tamperproof hardware is available on special order. All hardware is accessible from outside the base for easy installation. Halves are factory fitted and shipped together.

Each half is identical with an integral door designed to fit the aesthetic appearance of the base. Doors are supplied with stainless steel socket style screws.

Clamshell bases are designed to wrap around the pole with a circular hole with a tolerance of .25" maximum clear between the base and the casting. For fluted poles, the flutes start 1-2" above the top of the base for a clean appearance.

The finish for the base is polyester powder coating applied in accordance with Valmont Industries' Specifications.

The top opening dimensions are calculated using the pole base dimension and a taper rate of .14" per foot. The opening is designed to accommodate outside diameter of mandrel formed round tubes and point-to-point diameter of multi-sided tubes.

ALUMINUM Clamshell Base

CATALOG LOGIC

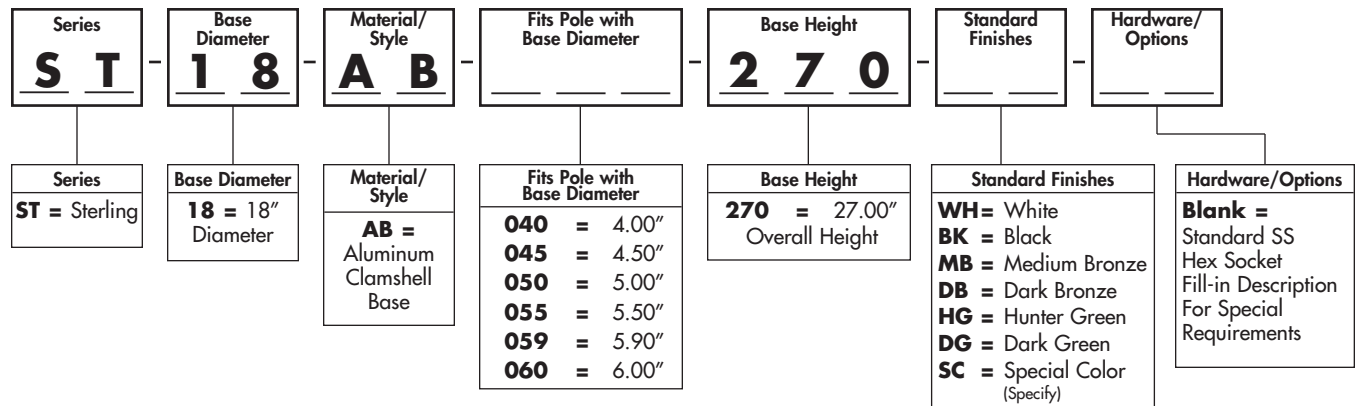

STERLING ST18-AB

18" ALUMINUM CLAMSHELL DECORATIVE BASE

BASE MOUNTING DETAIL

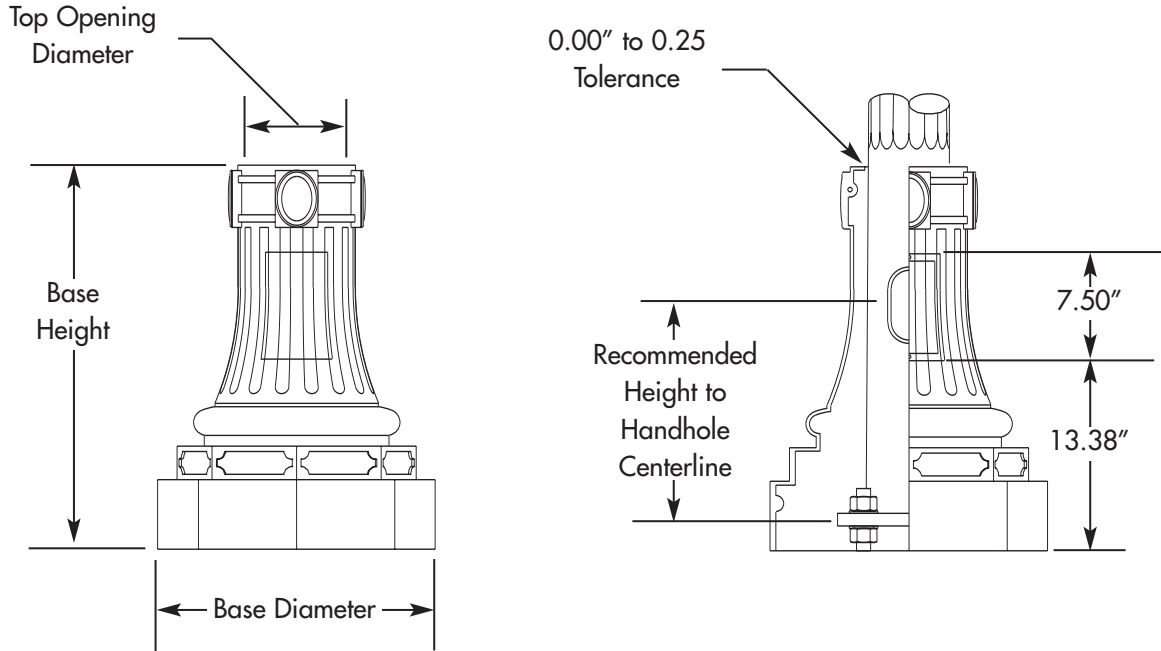

DIMENSIONAL DATA TABLE

DESCRIPTION	CATALOG NUMBER	BASE DIMENSIONS			POLE DIMENSIONS for BASE			HANDHOLE	
		TOP OPENING DIAMETER (IN)	BASE DIAMETER (IN)	BASE HEIGHT (IN)	POLE BASE DIAMETER (IN)	POLE DIA. @ TOP OF BASE (IN)	MAX. BASE PLATE DIAGONAL (IN)	STANDARD HANDHOLE SIZE (IN)	HANDHOLE HEIGHT TO CENTER (IN)
STERLING 18"	ST18AB-040-270-(F)-(O)	4.00	18.00	27.00	4.00	3.69	17.00	2.5 x 5	15.50
STERLING 18"	ST18AB-045-270-(F)-(O)	4.50	18.00	27.00	4.50	4.19	17.00	2.5 x 5	15.50
STERLING 18"	ST18AB-050-270-(F)-(O)	5.00	18.00	27.00	5.00	4.69	17.00	2.5 x 5	15.50
STERLING 18"	ST18AB-055-270-(F)-(O)	5.50	18.00	27.00	5.50	5.19	17.00	2.5 x 5	15.50
STERLING 18"	ST18AB-059-270-(F)-(O)	5.75	18.00	27.00	5.90	5.59	17.00	2.5 x 5	15.50
STERLING 18"	ST18AB-060-270-(F)-(O)	6.00	18.00	27.00	6.00	5.69	17.00	2.5 x 5	15.50

Note: Replace (F) with Finish Selection and (O) with Hardware/Option Selection.