

SPECIFICATIONS

Pole

The Williamsburg pole is available in 8' to 14' including a cast aluminum structural base with a tapered round aluminum shaft. The pole is designed to accommodate a twin arm assembly up to a 36" overall span.

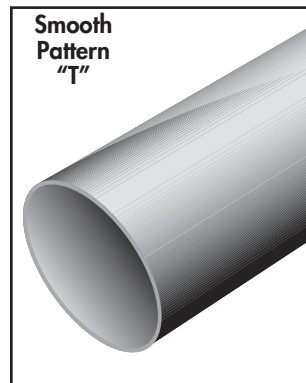

Shaft

The shaft is seamlessly extruded from 6063 aluminum alloy. After being spun tapered, the shaft is inserted and welded into the decorative structural base casting.

Structural Base

The structural base is cast from A356 aluminum alloy. A continuous circumferential weld at the top and inside of the base joins the structural base casting and shaft. The anchor bolts are located inside the base. Special covers are provided to conceal the anchor bolts. The completed assembly is heat-treated to T6 temper after all structural welding is completed.

Access Door

An access door is provided to install and service the ground connector and circuit wiring. The door is 11.50" in height and 3.00" in width and fits to the base with stainless steel hardware.

Anchor Bolts

Anchor bolts are fabricated from carbon steel bar conforming to the requirements of ASTM F1554 Grade 55. The upper 12" of the bolts are hot dip galvanized per ASTM A153. Each anchor bolt is supplied with two hex nuts and two flat washers.

Electrical Ground Connector

A nut holder is provided in the base and accessible from the access door. The nut holder includes a tapped 3/8"-16 UNC bolt.

Finish

The finish for the pole is polyester powder coating applied over chromate pre-treatment in accordance with Valmont Industries' Specifications.

CATALOG LOGIC

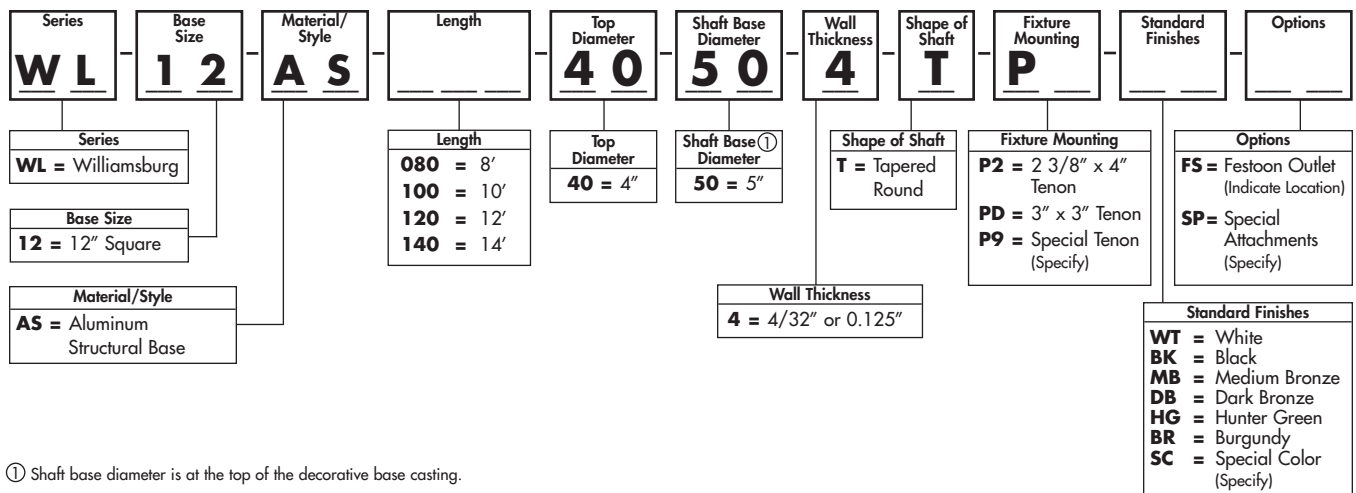

① Shaft base diameter is at the top of the decorative base casting.

WILLIAMSBURG WL12-AS STRUCTURAL 8' TO 14' TAPERED ROUND

ANCHOR BASE AND BOLT DIMENSIONS

Base Dimensions

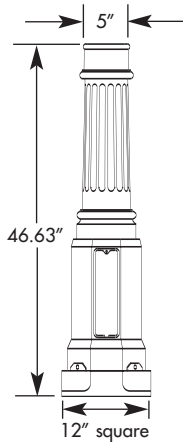

Bolt Projection Detail

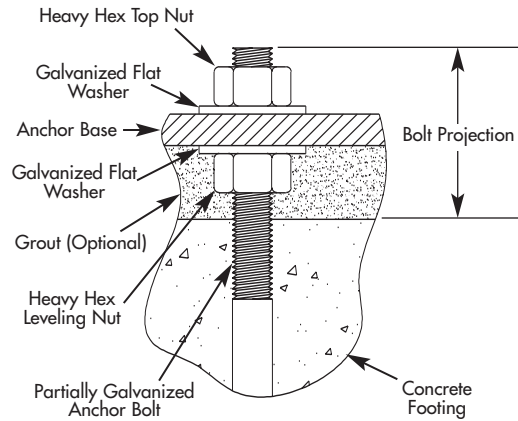

Anchor Base Detail

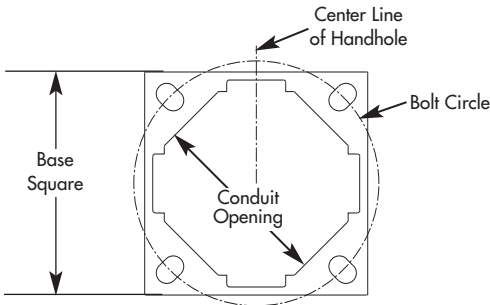

BASE DESCRIPTION	BOLT CIRCLE		ANCHOR BOLT		
	DIA. (IN)	± (IN)	DIA. X LENGTH X HOOK (IN)	PROJECTION (IN)	± (IN)
WL12-AS	13.25	0.50	0.75 x 17.00 x 3.00	3.50	0.25

STANDARD AND DIMENSIONAL DATA TABLE

POLE HEIGHT (FT)	CATALOG NUMBER	SHAFT				80 MPH [Ⓐ]		90 MPH [Ⓐ]		100 MPH [Ⓐ]	
		TOP O.D. (IN)	BASE O.D. (IN)	WALL THK. (IN)	STRUCTURAL WEIGHT (LBS)	MAX EPA (SQ FT)	MAX WEIGHT (LBS)	MAX EPA (SQ FT)	MAX WEIGHT (LBS)	MAX EPA (SQ FT)	MAX WEIGHT (LBS)
8	WL12AS-080-40504T	4.00	5.00	0.125	79	21.9	300	17.0	300	13.4	300
10	WL12AS-100-40504T	4.00	5.00	0.125	83	15.5	300	11.8	300	9.1	300
12	WL12AS-120-40504T	4.00	5.00	0.125	87	11.2	300	8.3	300	6.2	300
14	WL12AS-140-40504T	4.00	5.00	0.125	91	8.1	300	5.7	300	4.0	300

[Ⓐ] EPA values are calculated in accordance with AASHTO Specifications for Structural Supports for Highway Signs, Luminaires and Traffic Signals, 1994.

EPA calculations allow for 1.3 Wind Gust Factor. Variations from standard sizes listed above, are available upon inquiry at the factory. Satisfactory performance of lighting standard is dependent upon the pole(s) being properly attached to a supporting foundation of adequate design. Valmont Industries does not design or offer recommendations for foundations.