

**"BCAS" Low Base Series**

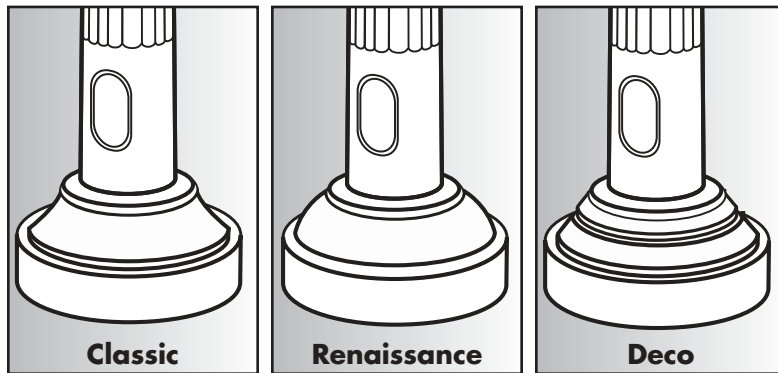

**"BCAF" High Base Series**

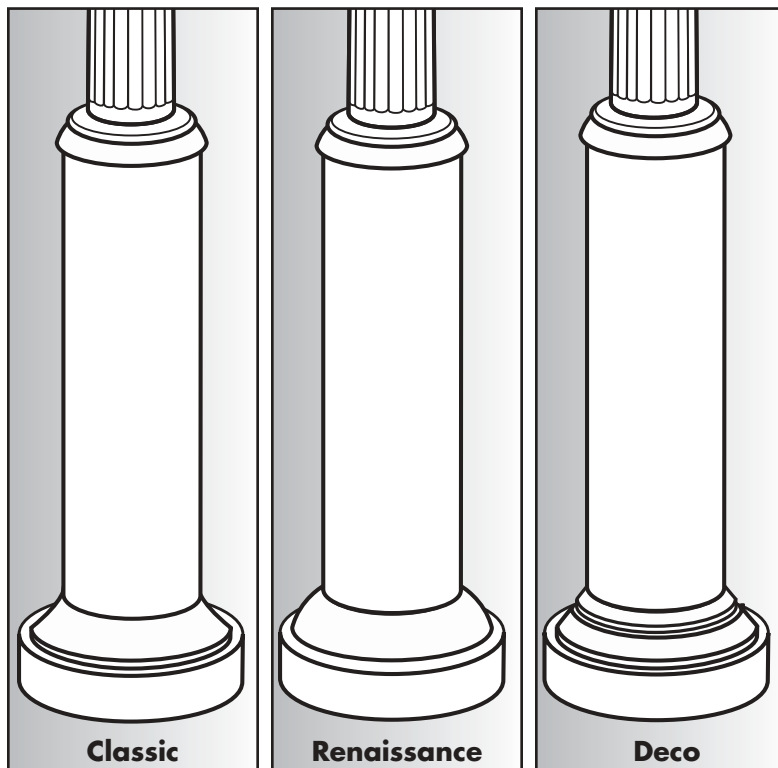

**SPECIFICATIONS**

**Low Bases "BCAS" Series:** Low base assemblies are manufactured from one-piece spun aluminum and are non-structural in nature. The aluminum is alloy 1100 and spun to an approximate thickness of .125" to minimize vandalism and damage. The top hole that the pole passes through is punched based on the specified pole base diameter. The low bases can accommodate poles with base diameters of 6", 7", 8" and 9". A soft radius area is punched out of one side to allow clearance for the semi-flush handhole. The base is sanded after spinning to provide an appropriate surface for adhesion of powder coated finish.

**High Bases "BCAF" Series:** High base assemblies are manufactured by factory assembling two one-piece spun aluminum collars and a section of 10" diameter extruded tube. These bases are designed to be non-structural in nature. The aluminum used in the spun collars is alloy 1100 and .125" thick to minimize vandalism and damage. The extruded tube is .188" wall alloy 6063 aluminum. The top hole that the pole passes through is punched based on the specified pole base diameter. The components are welded together at the factory with all welds located on the inside away from view. A flush 4" x 6" handhole is provided at 11" above the top of the base to align with the pole handhole. This allows access to wiring without lifting the base. The high base assemblies can accommodate poles with base diameters of 6", 7" and 8". These bases are not available for 9" diameter base poles. The entire base assembly is sanded after spinning to provide an appropriate surface for adhesion of powder coated finish and to conceal the handhole.

**Installation of Base Assembly:** Bases are designed for "Drop-Over" installation and must be placed over the top of the pole during erection. This must occur prior to mounting of luminaires and luminaire arms to the pole. This approach provides for a clean seamless appearance when installation is complete.

**Finishes:** The finish for the base assemblies is polyester powder applied coating in accordance with Valmont Industries' Specifications. Base assemblies may have finishes selected individually to match pole or elements of the pole top assembly.

**CATALOG LOGIC**

<b>BASE</b> <b>B C</b>	<b>MATERIAL</b> <b>A</b> _	<b>STYLE</b> _	<b>SIZE</b> _	<b>POLE BASE DIAMETER</b> _	<b>FINISH</b> _ _
<b>BASE</b> BC = Base Assembly	<b>MATERIAL</b> AS = Spun Aluminum Drop-over AF = Fabricated Spun and Extruded Aluminum Drop-over	<b>STYLE</b> C = Classic R = Renaissance D = Deco	<b>SIZE</b> ① L = Low H = High	<b>POLE BASE DIAMETER</b> ① 6 = 6" 7 = 7" 8 = 8" 9 = 9"	<b>FINISH</b> WH = White BK = Black MB = Medium Bronze SG = Slate Grey ST = Sandstone SL = Silver BR = Burgandy RD = Red CG = Copper Green BG = Blue Green HG = Hunter Green AB = Azure Blue BV = Dark Blue Violet SC = Special Color (Please Specify)

① "H" high base is not available for 9" base diameter poles.



# BASE ASSEMBLIES "BCAS" AND "BCAF" SERIES

## CLASSIC DIMENSIONS

"BCAF" High Base

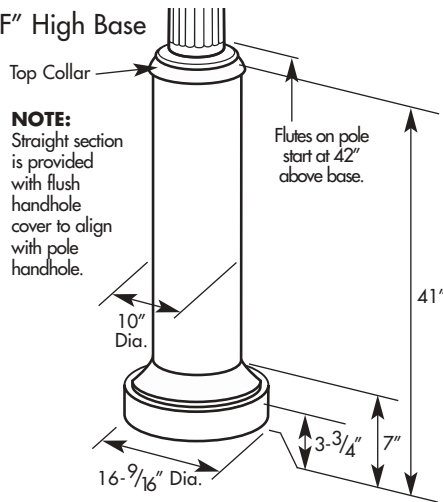

"BCAS" Low Base

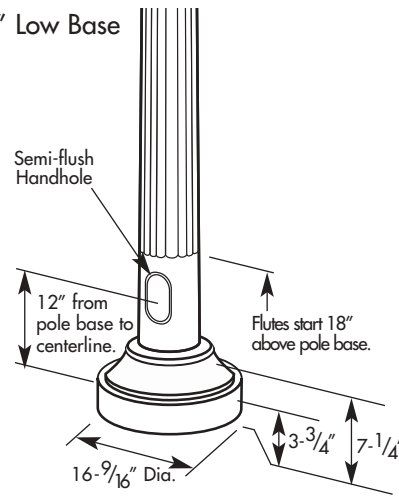

### SPECIFICATION NOTES

- "BCAF" series high bases are designed for use with poles having "HT" or "HS" fluting layouts. They may also be used with City Quartz smooth "210" series poles. "BCAF" bases will not fit up to poles with "LT" or "LS" fluting patterns.
- "BCAS" series low bases may be used with all City Quartz fluted or smooth poles.

## RENAISSANCE DIMENSIONS

"BCAF" High Base

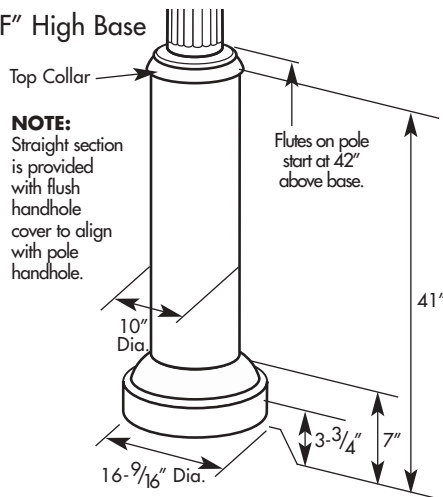

"BCAS" Low Base

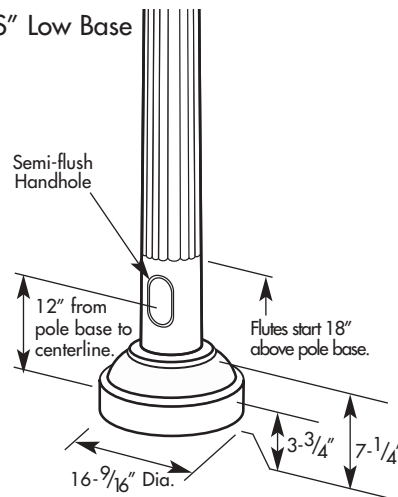

### SPECIFICATION NOTES

- "BCAF" series high bases are designed for use with poles having "HT" or "HS" fluting layouts. They may also be used with City Quartz smooth "210" series poles. "BCAF" bases will not fit up to poles with "LT" or "LS" fluting patterns.
- "BCAS" series low bases may be used with all City Quartz fluted or smooth poles.

## DECO DIMENSIONS

"BCAF" High Base

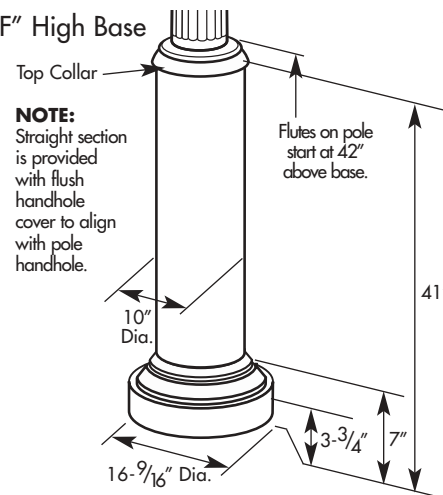

"BCAS" Low Base

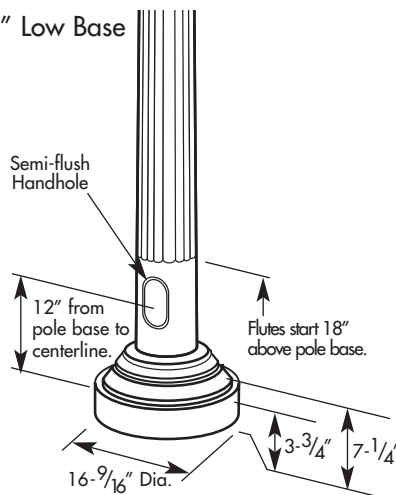

### SPECIFICATION NOTES

- "BCAF" series high bases are designed for use with poles having "HT" or "HS" fluting layouts. They may also be used with City Quartz smooth "210" series poles. "BCAF" bases will not fit up to poles with "LT" or "LS" fluting patterns.
- "BCAS" series low bases may be used with all City Quartz fluted or smooth poles.