

**Flute Layout Options**

**SPECIFICATIONS**

**Pole:** Fluted poles are formed from tubes conforming to the ASTM A595 process with a constant linear taper of 0.14"/ft. The wall thickness is available in 11 ga. (0.1196") or 7 ga. (0.1793"). The tube's seam weld is formed by the Electric Resistance Weld (ERW), and is smooth with no visual appearance.

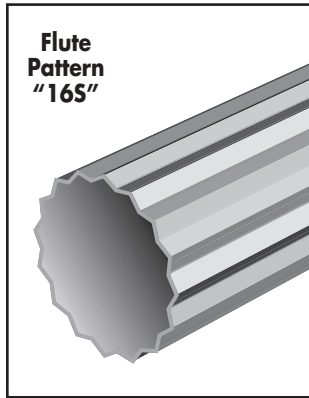

**Flute Pattern "16S"**

**Fluting Process:** The poles are cold rolled over a precision hardened steel mandrel to form the fluted shape indicated. The fluted shaft has uniform Doric flutes. The flutes are formed with rollers in full contact with the material from the top of the crest, through the valley of the flute, to the top of the next crest. The termination of the flutes is no greater than 1-1/2" radii transition into the round section of the pole.

**Semi-flush Handhole:** The reinforcing handhole rim consists of a nominal 2-1/2" x 5" oval shaped pipe material. The handhole is provided with a steel attachment bar, steel cover and one round head machine screw. The handhole is welded with the rim extending 1/4" out of the pole shaft and shaped to match the diameter of the pole.

**Pole Top Tenon:** Pole top tenons are fabricated from structural quality hot rolled carbon steel with yield strength of 30,000 psi. A pole top plate of hot rolled commercial quality carbon steel is welded to the top of the pole shaft.

**Anchor Bolts and Base Plate:** Anchor bolts are fabricated from carbon steel bar conforming to the requirements of ASTM F1554 Grade 55. The upper 12" of the bolts are hot dip galvanized per ASTM A153. Each anchor bolt is supplied with two hex nuts and two flat washers. Base plates conform to ASTM A36 and are integrally welded to the tubes with a socket welded joint.

**Pole Top Cap:** A removable cap is provided in conjunction with drilled shafts for direct luminaire arm attachment.

**Decorative Nut Covers:** The optional decorative nut covers are manufactured of a sandcast aluminum alloy 356.2 and are attached to the pole using stainless steel, self tapping hex head screws.

**Electrical Ground:** A nut holder is provided near the handhole and includes a 1/2" - 13UNC hex head bolt and nut.

**Finish:** The finish for the pole is polyester powder applied coating in accordance with Valmont Industries' Specifications.

**CATALOG LOGIC**

SERIES	MATERIAL	BASE DIAMETER	POLE CROSS SECTION	SHAFT THICKNESS	FLUTE LAYOUT	LENGTH	FIXTURE MOUNTING	FINISH	OPTIONS
<b>C Q S</b>			<b>1 6 S</b>						
<b>SERIES</b> CQ = City Quartz	<b>MATERIAL</b> S = Steel	<b>BASE DIA. ①</b> 6 = 6.00" 7 = 7.00" 8 = 8.00" 9 = 9.00"	<b>POLE CROSS SECTION</b> 16S = 16 Sharp Flute	<b>SHAFT THICKNESS ①</b> AF = 11 Ga. Fluted EF = 7 Ga. Fluted	<b>FLUTE LAYOUT</b> HT = Start 42" from Base Run to Top of Pole LT = Start 18" from Base Run to Top of Pole HS = Start 42" from Base Stop 9" from Top of Pole LS = Start 18" from Base Stop 9" from Top of Pole	<b>LENGTH ①</b> 080 = 8'-0" 100 = 10'-0" 120 = 12'-0" 140 = 14'-0" 160 = 16'-0" 180 = 18'-0" 200 = 20'-0" 250 = 25'-0" 300 = 30'-0" 350 = 35'-0" 390 = 39'-0"	<b>FIXTURE MOUNTING</b> PQ = 2-3/8" x 12" Tenon for PT Assembly P2 = 2-3/8" x 4" Tenon PD = 3" x 3" Tenon D2 = Drilling for 1 or 2 Luminaires D4 = Drilling for 2 @ 90, 3 @ 90, or 4 @ 90 D3 = Drilling for 3 @ 120 *Specify fixture type and manufacturer for drilling pattern at time of order.	<b>STANDARD FINISHES</b> WH = White BK = Black MB = Medium Bronze SG = Slate Grey ST = Sandstone SL = Silver BR = Burgandy RD = Red CG = Copper Green BG = Blue Green HG = Hunter Green AB = Azure Blue BV = Dark Blue Violet SC = Special Color (Please Specify)	<b>OPTIONS</b> NC = Fluted Nut Covers SL = Special Pole Length (Please Specify)

① For available base diameter, wall thickness and length combinations, see Dimensional and Load Data table that follows.



# 8' TO 39' ROUND TAPERED 16 SHARP FLUTE "16S" SERIES

**valmont**

STRUCTURES

**CITY QUARTZ STEEL**

## ANCHOR BASE AND BOLT DIMENSIONS

### Semi-Flush Steel Reinforced Handhole

The handhole is a unique semi-flush reinforced design. Rim is curved to match pole diameter in the smooth section of the pole and extends only 1/4" from the pole surface.

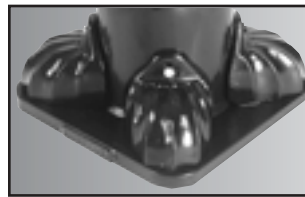

### Cast Nut Cover

When ordering poles without base assembly, cast nut cover option can be specified to provide an attractive pole base finish.

### Anchor Base Detail

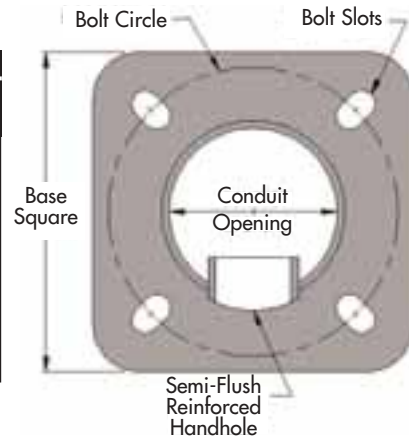

POLE DIA. (IN)	BASE DIMENSIONS (SEE DETAIL)				ANCHOR BOLTS	
	BOLT CIRCLE	BASE SQUARE	CONDUIT OPENING	BASE THK.	BOLT SIZE	BOLT PROJECT.
6.00"	9.50" ± 0.50"	10.50"	5.50"	0.75"	0.75" x 17.00" x 3.00"	3.50" ± 0.25"
7.00"	10.00" ± 0.50"	11.00"	6.50"	1.00"	1.00" x 36.00" x 4.00"	4.25" ± 0.25"
8.00"	11.00" ± 0.50"	11.75"	7.50"	1.00"	1.00" x 36.00" x 4.00"	4.25" ± 0.25"
9.00" <sup>1</sup>	12.50" ± 0.50"	12.00"	8.50"	1.25"	1.25" x 42.00" x 6.00"	5.00" ± 0.25"
9.00" <sup>2</sup>	12.50" ± 0.50"	13.50"	8.50"	1.25"	1.25" x 42.00" x 6.00"	5.00" ± 0.25"

<sup>1</sup> Pole Diameter includes base cover.

<sup>2</sup> Pole Diameter includes nut covers.

## STANDARD DIMENSIONAL AND LOAD DATA

POLE HEIGHT (FT)	CATALOG NUMBER <sup>(A)</sup>	SHAFT				80 MPH <sup>(B)</sup>		90 MPH <sup>(B)</sup>		100 MPH <sup>(B)</sup>	
		BASE O.D. (IN)	TOP O.D. (IN)	WALL THK. (GA)	STRUCT. WEIGHT (LBS)	MAX EPA (SQ FT)	MAX WEIGHT (LBS)	MAX EPA (SQ FT)	MAX WEIGHT (LBS)	MAX EPA (SQ FT)	MAX WEIGHT (LBS)
8	CQS-6-16S-AF-(FL)-080-(M)-(F)-(O)	6.00	4.88	11	82	28	260	22	260	18	260
10	CQS-6-16S-AF-(FL)-100-(M)-(F)-(O)	6.00	4.60	11	94	18	260	14	260	11	260
12	CQS-6-16S-AF-(FL)-120-(M)-(F)-(O)	6.00	4.32	11	106	15	260	12	260	9	260
14	CQS-6-16S-AF-(FL)-140-(M)-(F)-(O)	6.00	4.04	11	116	13	260	10	260	7	260
16	CQS-6-16S-AF-(FL)-160-(M)-(F)-(O)	6.00	3.76	11	126	11	260	8	260	6	260
16	CQS-7-16S-AF-(FL)-160-(M)-(F)-(O)	7.00	4.76	11	151	24	260	18	260	14	260
18	CQS-7-16S-AF-(FL)-180-(M)-(F)-(O)	7.00	4.48	11	163	21	260	15	260	12	260
20	CQS-7-16S-AF-(FL)-200-(M)-(F)-(O)	7.00	4.20	11	174	18	260	13	260	10	260
20	CQS-8-16S-AF-(FL)-200-(M)-(F)-(O)	8.00	5.20	11	203	23.5	260	17.5	260	13	260
25	CQS-7-16S-AF-(FL)-250-(M)-(F)-(O)	7.00	3.50	11	199	11	260	8	260	5	260
25	CQS-8-16S-AF-(FL)-250-(M)-(F)-(O)	8.00	4.50	11	234	15.5	260	10.5	260	7.5	260
30	CQS-8-16S-AF-(FL)-300-(M)-(F)-(O)	8.00	3.80	11	261	11	260	7	260	4	260
30	CQS-9-16S-AF-(FL)-300-(M)-(F)-(O)	9.00	4.80	11	307	17.5	260	12	260	8	260
30	CQS-9-16S-EF-(FL)-300-(M)-(F)-(O)	9.00	4.80	7	436	24.5	260	17.5	260	12.5	260
35	CQS-9-16S-AF-(FL)-350-(M)-(F)-(O)	9.00	4.10	11	335	12.5	260	7.5	260	4.5	260
35	CQS-9-16S-EF-(FL)-350-(M)-(F)-(O)	9.00	4.10	7	478	19	260	13	260	8.5	260
39	CQS-9-16S-AF-(FL)-390-(M)-(F)-(O)	9.00	3.54	11	355	9	260	5	260	2	260
39	CQS-9-16S-EF-(FL)-390-(M)-(F)-(O)	9.00	3.54	7	507	15	260	9.5	260	6	260

SPC7010 06/05

<sup>(A)</sup> Replace (FL) with Fluting Layout Code, (M) with Fixture Mounting Method Code, (F) with Finish Code and (O) with Options Code.

<sup>(B)</sup> EPA calculations allow for 1.3 Wind Gust Factor. Variations from standard sizes listed above, available upon inquiry at the factory. Satisfactory performance of lighting standard is dependent upon the pole(s) being properly attached to a supporting foundation of adequate design. Valmont Industries does not design or offer recommendations for foundations.